

RHINOFEET™

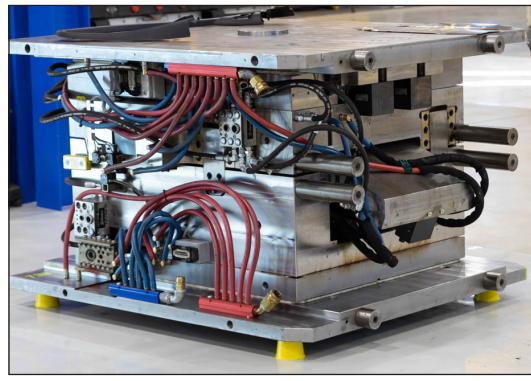

Progressive offers the RhinoFeet product line to eliminate the hazards associated with placing molds and plates on wood blocks and pallets.

- Safer, cleaner, and improves 5S standards within the shop.
- 7,000 lbs (3,000 kg) or 15,000 lbs (7,000 kg) safe working loads, with a safety factor of 3.
- Height and load is marked on the feet for easy identification.

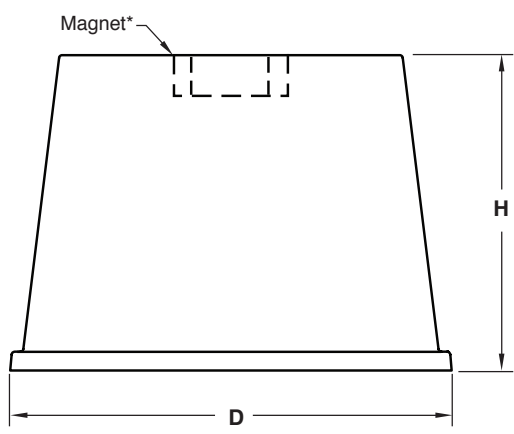

CATALOG NUMBER INCH	CATALOG NUMBER METRIC	D	H	SAFE WORKING LOAD (LBS/KG)
RHF2	RHF50	4.12" / 104mm	2" / 50mm	7,000 / 3,000
RHF3	RHF75	4.12" / 104mm	3" / 75mm	7,000 / 3,000
RHF4	RHF100	4.12" / 104mm	4" / 100mm	7,000 / 3,000
RHF5	RHF125	5.43" / 140mm	5" / 125mm	15,000 / 7,000

*Note: The RHF5/RHF125 has 2 magnets.

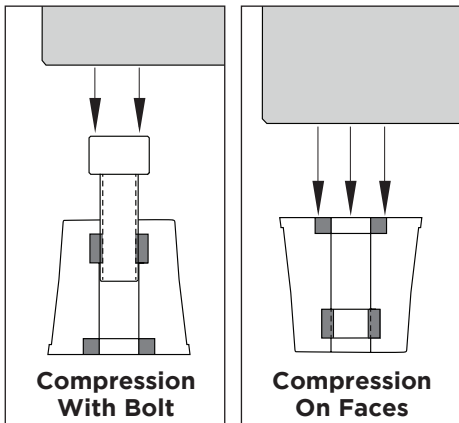
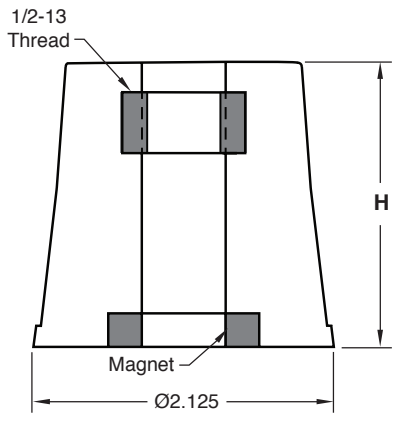

RHINOTOES™



CATALOG NUMBER	H	COMPRESSION WITH BOLT SAFE WORKING LOAD (LBS/KG)	COMPRESSION ON FACES SAFE WORKING LOAD (LBS/KG)
RHT1	1"	630 / 286	2,500 / 1,000
RHT2	2"	800 / 363	2,500 / 1,000
RHT3	3"	830 / 377	2,500 / 1,000

APPLICATION GUIDELINES

- RhinoToes are utilized to support a plate or hot runner system for bench work or storage.
- Use with a 1/2-13 bolt or threaded rod for additional heights and plate separation.
- RhinoToes have a safety factor of 3.
- Mold maker to supply 1/2-13 threaded rod or bolt.