

FLEXICORE™

UNDERCUT RELEASE SYSTEM

Flats prevent twisting and ensure proper alignment.

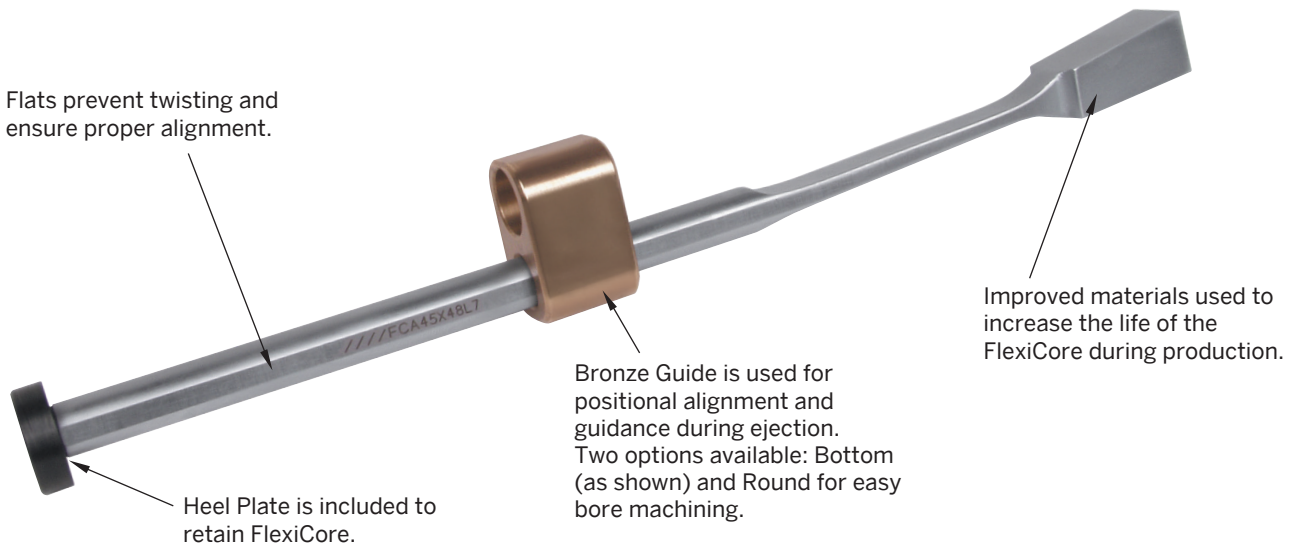

Heel Plate is included to retain FlexiCore.

Bronze Guide is used for positional alignment and guidance during ejection. Two options available: Bottom (as shown) and Round for easy bore machining.

Improved materials used to increase the life of the FlexiCore during production.

FlexiCore Assembly includes: FlexiCore, Bronze Guide (Bottom or Round), Heel Plate, and Flat Head Cap Screw.

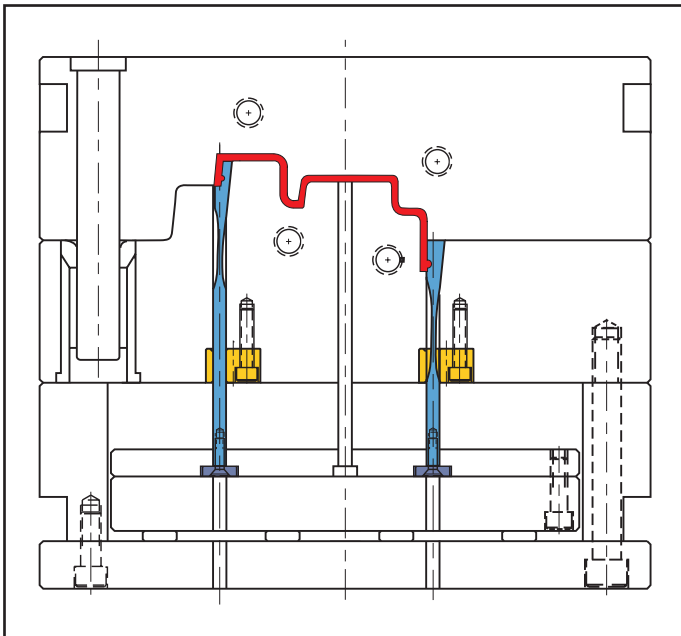

Mold Closed

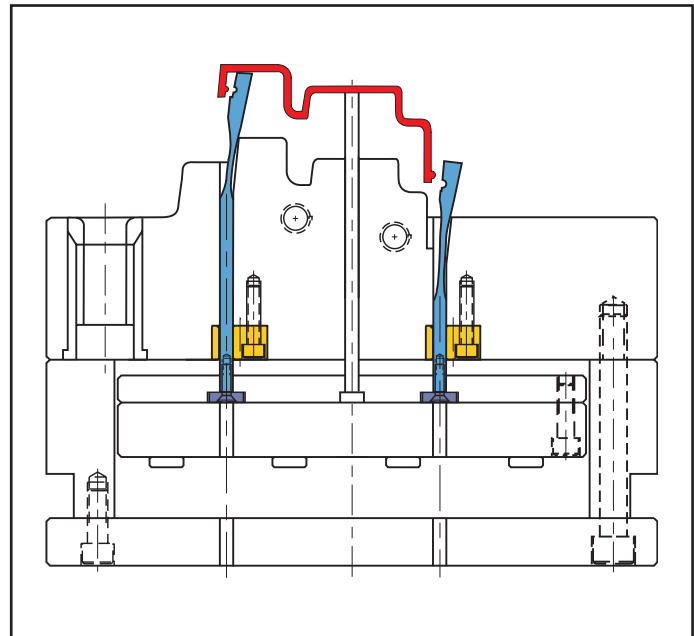

Mold Open

Application Guidelines:

- The FlexiCore diameter (D) must be within the Guide prior to ejection as shown above.
- Only surface treatments applied at low temperatures such as Electroless Nickel-based or chromium deposition treatments are permitted.
- Maximum temperature is 250° F (125° C).
- Please contact tech@procomps.com to review any designs if questions arise or if your application differs from the examples shown.

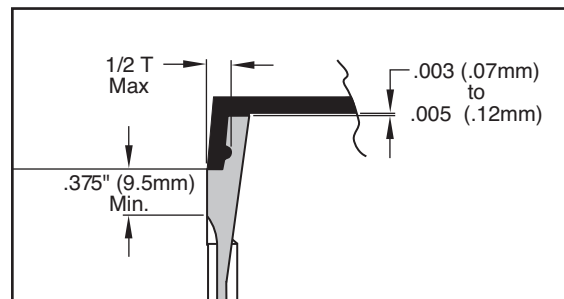



FLEXICORE™ BOTTOM GUIDE ASSEMBLY

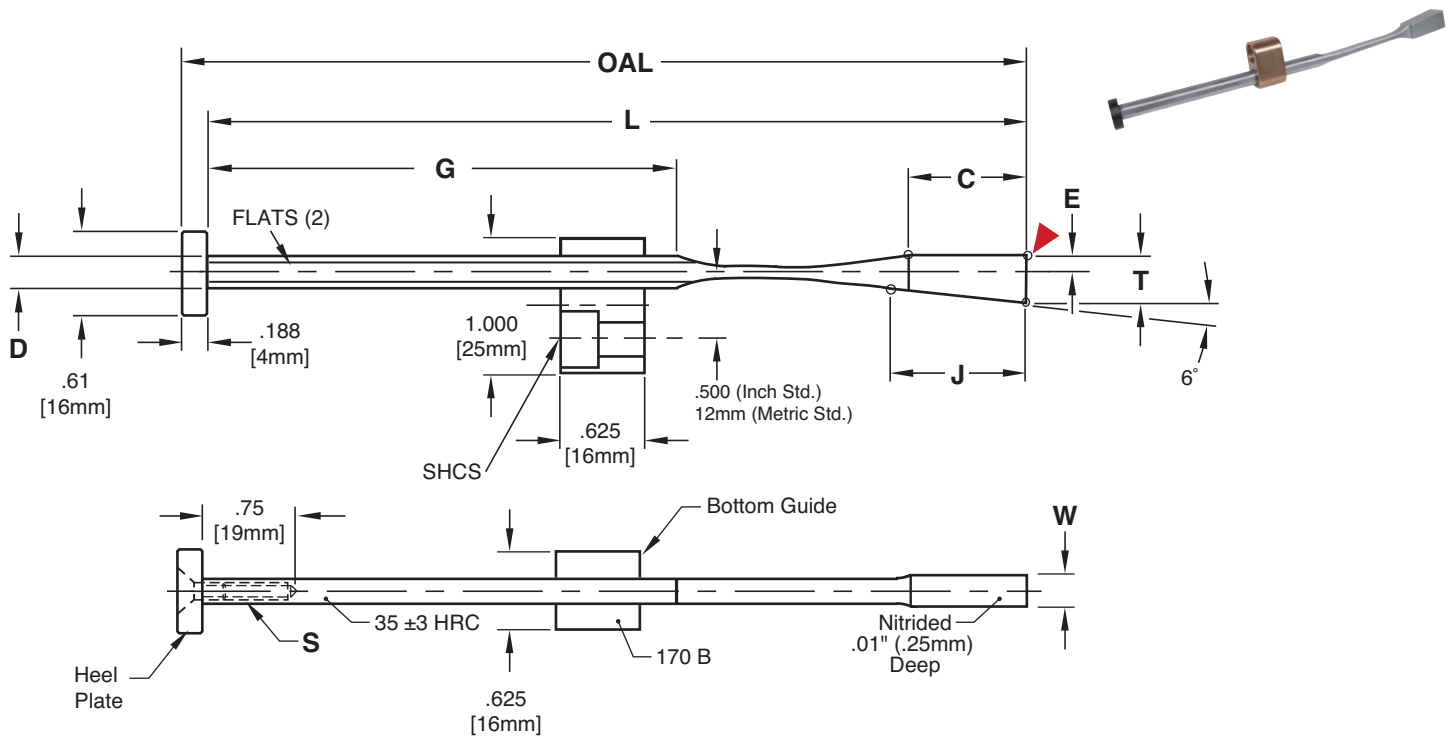

Design Guidelines:

- The FlexiCore can be cut down and re-tapped to accommodate specific applications.

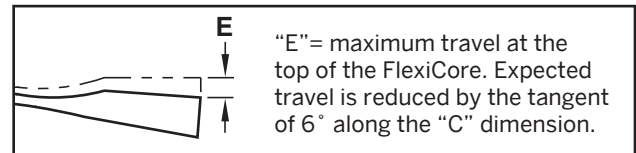

Inch Standard

M FlexiCore: AISI 4340 with thin, dense Chromium treatment, Guide: CA954 Solid Bronze, Heel Plate: AISI 1018

▶ CAD insertion point

CATALOG NUMBER	T +.002 -.000	W +.002 -.000	L +.010 -.000	OAL REF	D +.000 -.001	C ± .015	E	G +.01 -.00	J	S (Included)	SHCS
FCA35X24L6	.354	.244	6.400	6.588	.234	.875	.137	3.49	.957	#8-32 x 3/8	1/4-20
FCA35X32L6	.354	.322	6.400	6.588	.250	.875	.137	3.48	.957	#8-32 x 3/8	1/4-20
FCA45X40L7	.453	.401	7.875	8.062	.312	1.000	.177	4.38	1.025	#10-24 x 1/2	1/4-20
FCA45X48L7	.453	.480	7.875	8.062	.312	1.000	.177	4.38	1.025	#10-24 x 1/2	1/4-20

Metric Standard

CATALOG NUMBER	T +.05 -.00	W +.05 -.00	L +.25 -.00	OAL REF	D +.000 -.025	C ± .35	E	G +.25 -.00	J	S (Included)	SHCS
FCA9X6L160	9	6.2	162.5	166.5	5.94	22	3.5	88.6	24.3	M4-0.7 x 12	M6-1
FCA9X8L160	9	8.2	162.5	166.5	6.35	22	3.5	88.4	24.3	M4-0.7 x 12	M6-1
FCA11X10L200	11.5	10.2	200.0	204.0	7.92	26	4.5	111.2	26.0	M5-0.8 x 14	M6-1
FCA11X12L200	11.5	12.2	200.0	204.0	7.92	26	4.5	111.2	26.0	M5-0.8 x 14	M6-1
FCA12X14L200	12.5	14.2	200.0	204.0	7.92	30	4.5	107.2	28.5	M5-0.8 x 14	M6-1
FCA12X16L200	12.5	16.2	200.0	204.0	7.92	30	4.5	107.2	28.5	M5-0.8 x 14	M6-1

Assemblies include: FlexiCore, Bottom Guide, Heel Plate, and Flat Head Cap Screw.
Assembly components also sold individually on page H-21.

FLEXICORE™

ROUND GUIDE ASSEMBLY

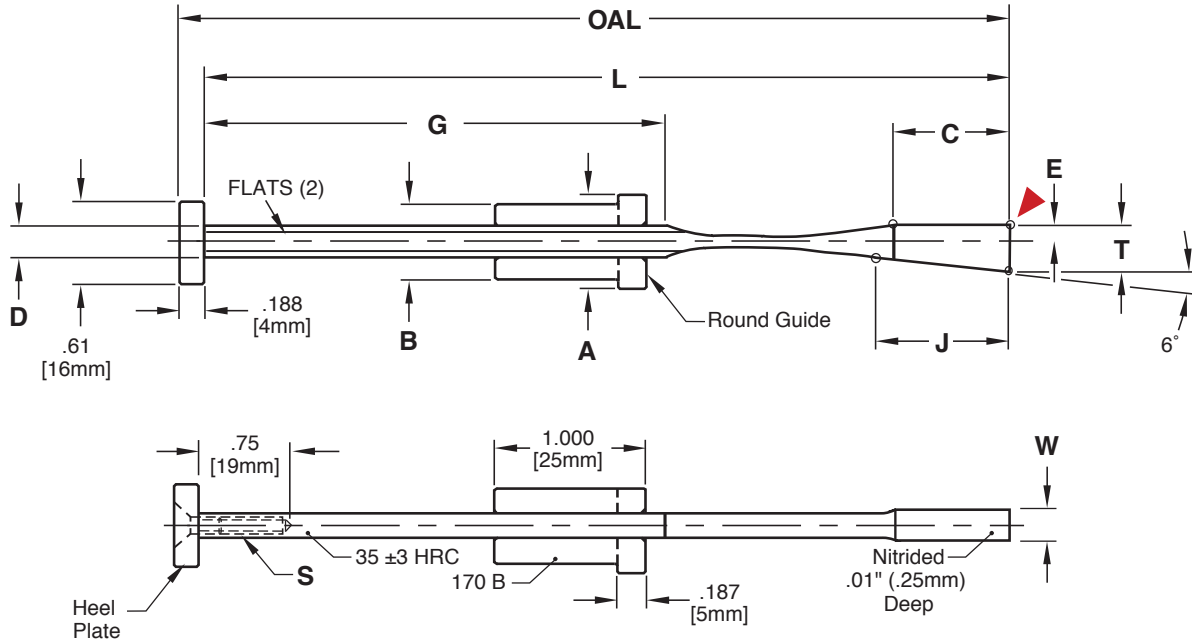

Design Guidelines:

- The FlexiCore can be cut down and re-tapped to accommodate specific applications.

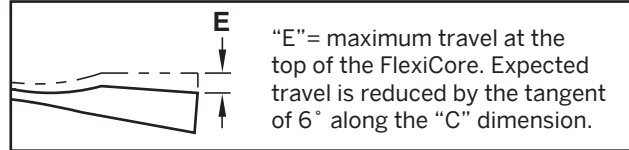

Inch Standard

M FlexiCore: AISI 4340 with thin, dense Chromium treatment, Guide: CA954 Solid Bronze, Heel Plate: AISI 1018

CATALOG NUMBER	T +.002 -.000	W +.002 -.000	L +.010 -.000	OAL REF	D +.000 -.001	C ± .015	E	G +.01 -.00	J	S (Included)	A	B
FCR35X24L6	.354	.244	6.400	6.588	.234	.875	.137	3.49	.957	#8-32 x 3/8	.625	.500
FCR35X32L6	.354	.322	6.400	6.588	.250	.875	.137	3.48	.957	#8-32 x 3/8	.625	.500
FCR45X40L7	.453	.401	7.875	8.062	.312	1.000	.177	4.38	1.025	#10-24 x 1/2	.750	.625
FCR45X48L7	.453	.480	7.875	8.062	.312	1.000	.177	4.38	1.025	#10-24 x 1/2	.750	.625

▶ CAD insertion point

Metric Standard

CATALOG NUMBER	T +.05 -.00	W +.05 -.00	L +.25 -.00	OAL REF	D +.000 -.025	C ± .35	E	G +.25 -.00	J	S (Included)	A	B
FCR9X6L160	9	6.2	162.5	166.5	5.94	22	3.5	88.6	24.3	M4-0.7 x 12	16	12
FCR9X8L160	9	8.2	162.5	166.5	6.35	22	3.5	88.4	24.3	M4-0.7 x 12	16	12
FCR11X10L200	11.5	10.2	200.0	204.0	7.92	26	4.5	111.2	26.0	M5-0.8 x 14	20	16
FCR11X12L200	11.5	12.2	200.0	204.0	7.92	26	4.5	111.2	26.0	M5-0.8 x 14	20	16
FCR12X14L200	12.5	14.2	200.0	204.0	7.92	30	4.5	107.2	28.5	M5-0.8 x 14	20	16
FCR12X16L200	12.5	16.2	200.0	204.0	7.92	30	4.5	107.2	28.5	M5-0.8 x 14	20	16

Assemblies include: FlexiCore, Round Guide, Heel plate, and Flat head Cap Screw.
 Assembly components also sold individually. Refer to page H-21 for information.



FLEXICORE™ DOUBLE ACTUATION

The double action bottom guide allows for the FlexiCore System to be used to release boss details with undercuts. FlexiCore Double Assembly (FCDA) includes: two FlexiCores, one Bottom Guide, one Heel Plate, and two Low Head Cap Screws.

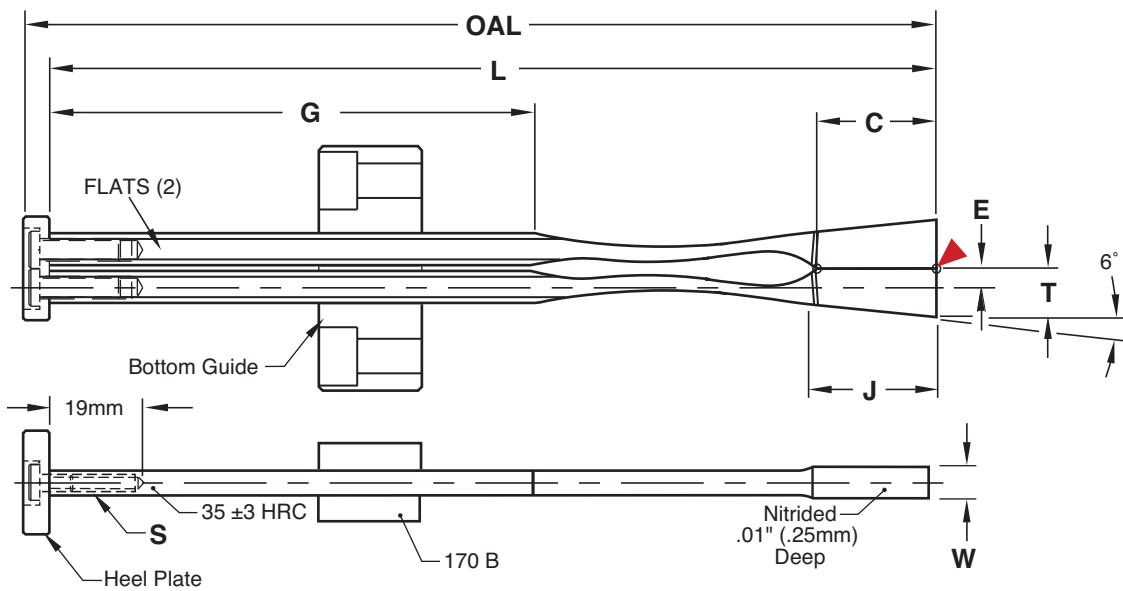
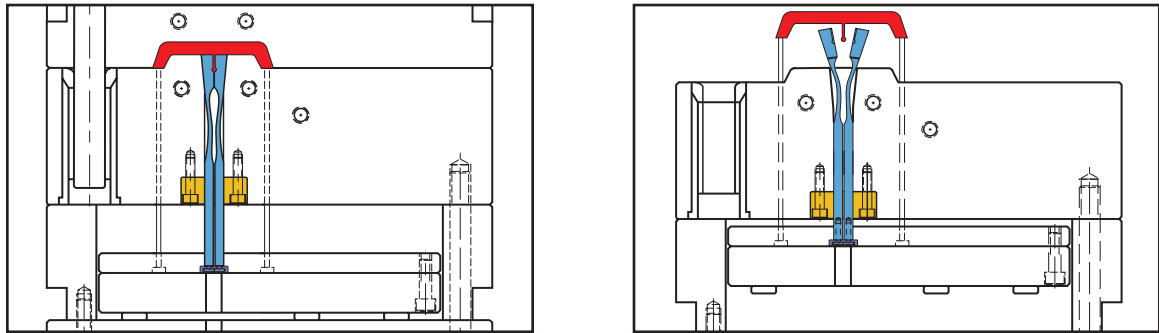

Design Guidelines:

- The FlexiCore can be cut down and re-tapped to accommodate specific applications.

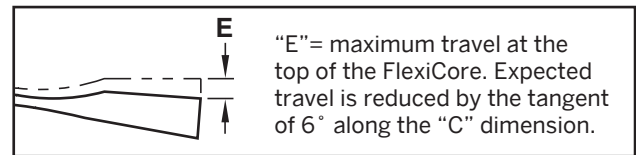

Inch Standard

M FlexiCore: AISI 4340 with thin, dense Chromium treatment, Guide: CA954 Solid Bronze, Heel Plate: AISI 1018

CATALOG NUMBER	T +.002 -.000	W +.002 -.000	L +.010 -.000	OAL REF	D +.000 -.001	C ±.015	E .015	G +.01 -.00	J +.01 -.00	S (Included-2)
FCDA35X24L6	.354	.244	6.400	6.588	.234	.875	.137	3.49	.957	#8-32 x 3/8
FCDA45X48L7	.453	.480	7.875	8.062	.312	1.000	.177	4.38	1.025	#10-24 x 1/2

Metric Standard

CATALOG NUMBER	T +.05 -.00	W +.05 -.00	L +.25 -.00	OAL REF	D +.000 -.025	C ±.035	E 015	G +.25 -.00	J +.01 -.00	S (Included-2)
FCDA9X6L160	9	6.2	162.5	166.5	5.94	22	3.5	88.6	24.3	M4-0.7 x 12
FCDA11X12L200	11.5	12.2	200.0	204.0	7.92	26	4.5	111.2	26.0	M5-0.8 x 14
FCDA12X14L200	12.5	14.2	200.0	204.0	7.92	30	4.5	107.2	28.5	M5-0.8 x 14
FCDA12X16L200	12.5	16.2	200.0	204.0	7.92	30	4.5	107.2	28.5	M5-0.8 x 14

▶ CAD insertion point

FLEXICORE™ ACCESSORIES

WEAR BLOCKS

Inch Standard

M P-20 Pre-Hard **H** Nitrided .005" Deep

CATALOG NUMBER	W +.002 -.000	D ± .01	B +.001 -.000	C +.001 -.000	H	K	T Thread
FCWB-24	.244	.250	.626	.533	1.000	.115	#10-24
FCWB-32	.322	.250	.626	.533	1.000	.115	1/4-20
FCWB-40	.401	.250	.567	.474	1.000	.115	1/4-20
FCWB-48	.480	.250	.567	.474	1.000	.115	1/4-20

Note: FCWB-24 is designed for use with a 1/4ø shoulder bolt.

Metric Standard

CATALOG NUMBER	W +.05 -.00	D ± .25	B +.025 -.000	C +.025 -.000	H	K	T Thread
FCWBM-6	6.2	7.2	15.9	13.55	25.4	2.9	M5-0.8
FCWBM-8	8.2	7.2	15.9	13.55	25.4	2.9	M6-1
FCWBM-10	10.2	7.2	14.4	12.05	25.4	2.9	M6-1
FCWBM-12	12.2	7.2	14.4	12.05	25.4	2.9	M6-1
FCWBM-14	14.2	8.0	15.2	12.11	33.2	3.5	M6-1
FCWBM-16	16.2	8.0	15.2	12.11	33.2	3.5	M6-1

▶ CAD insertion point

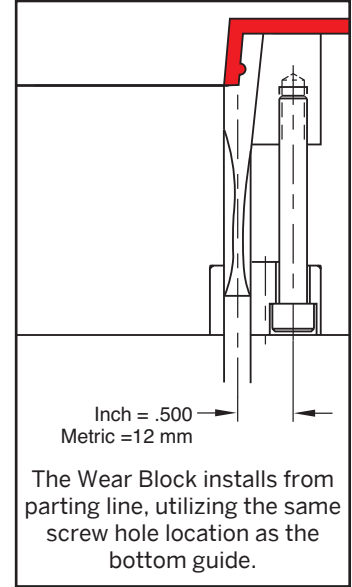
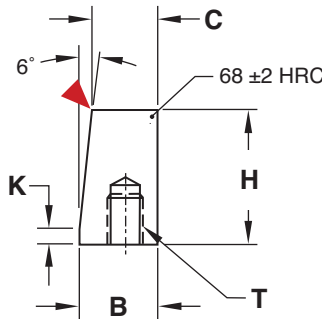
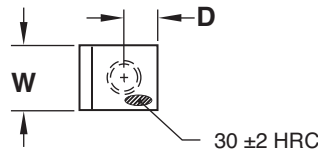

FLEXICORE™ ACCESSORIES

EXTENSIONS

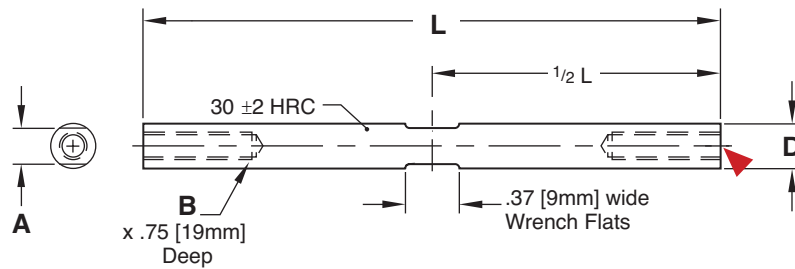
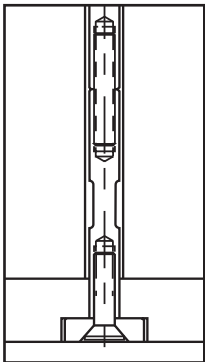

Inch Standard

M 4140 Pre-Hard

D +.000 -.005	B	A	L +.01 -.00	
			2"	4"
.232	#8-32	.187	FCX8L2	FCX8L4
.310	#10-24	.250	FCX10L2	FCX10L4

Metric Standard

D +.00 -.12	B	A	L +.25 -.00	
			50MM	100MM
6	M4-7	4.8	FCXM4L50	FCXM4L100
8	M5-.8	6.3	FCXM5L50	FCXM5L100

Includes threaded stud for attachment to FlexiCore.

▶ CAD insertion point



FLEXICORE™ ACCESSORIES

REPLACEMENT GUIDES

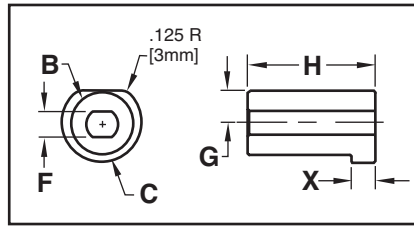
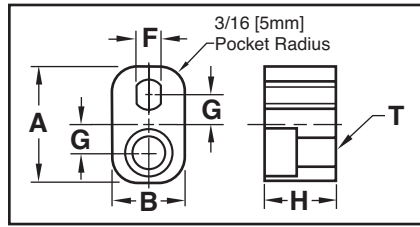

Inch/Metric Standard

M CA954 Solid Bronze

CATALOG NUMBER	A	B	H	F	G	T
FCBG-24	1.000	.625	.625	.190	.250	1/4-20
FCBG-32	1.000	.625	.625	.200	.250	1/4-20
FCBG-40	1.000	.625	.625	.290	.250	1/4-20
FCBG-6	25	16	16	4.8	6	M6-1
FCBG-8	25	16	16	5.0	6	M6-1
FCBG-10	25	16	16	7.3	6	M6-1

Inch/Metric Standard

M CA954 Solid Bronze

CATALOG NUMBER	B	C	H	F	X	G
FCRG-24	.5000	.625	1.000	.190	.187	.250
FCRG-32	.5000	.625	1.000	.200	.187	.250
FCRG-40	.6250	.750	1.000	.290	.187	.312
FCRG-6	12	16	25	4.8	5	6
FCRG-8	12	16	25	5.0	5	6
FCRG-10	16	20	25	7.3	5	8

Inch/Metric Standard

M 4140 Pre-Hard **H** Black Oxided

CATALOG NUMBER	K	P	S (Included)
FCHP-8	.61	.188	#8-32 x 3/8
FCHP-10	.61	.188	#10-24 x 1/2
FCHP-4	16	4	M4-0.7 x 12
FCHP-5	16	4	M5-0.8 x 14

REPLACEMENT HEEL PLATES

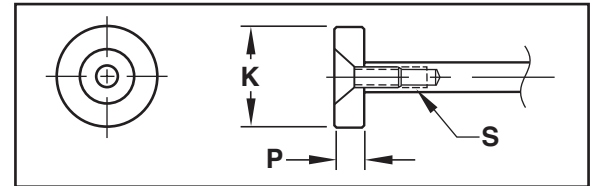

Inch/Metric Standard

M CA954 Solid Bronze

CATALOG NUMBER	A	B	H	F	G	R	S	T
FCDBG-24	1.750	.625	.750	.190	.136	.218	.636	1/4-20
FCDBG-48	1.875	.625	.750	.290	.176	.218	.676	1/4-20
FCDBG-6	45	16	20	4.8	3.5	5	15.5	M6-1
FCDBG-12	48	16	20	7.3	4.5	5	16.5	M6-1

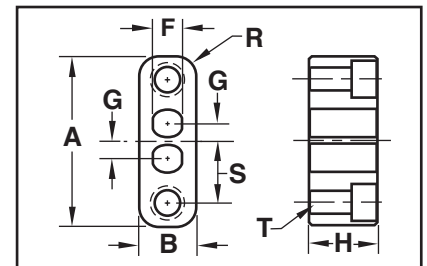

Inch/Metric Standard

M 4140 Pre-Hard **H** Black Oxided

CATALOG NUMBER	C	K	P	S (Included)
FCDHP-8	.272	.750	.188	#8-32 x 3/8
FCDHP-10	.352	.875	.188	#10-24 x 1/2
FCDHP-4	7	20	6	M4-0.7 x 12
FCDHP-5	9	22	6	M5-0.8 x 14

REPLACEMENT HEEL PLATES: DOUBLE ACTUATION

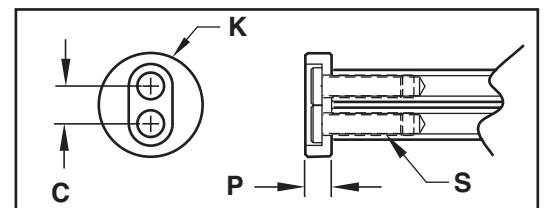

Screws included.